

SVENSKA

ITALIANO

ESPAÑOL

NEDERLANDS

DEUTSCH

FRANÇAIS

ENGLISH



marantz[®] Integrated Amplifier
PM7003
PM8003

User Guide

ENGLISH

WARRANTY

For warranty information, contact your local Marantz distributor.

RETAIN YOUR PURCHASE RECEIPT

Your purchase receipt is your permanent record of a valuable purchase. It should be kept in a safe place to be referred to as necessary for insurance purposes or when corresponding with Marantz.

IMPORTANT

When seeking warranty service, it is the responsibility of the consumer to establish proof and date of purchase. Your purchase receipt or invoice is adequate for such proof.

FOR U.K. ONLY

This undertaking is in addition to a consumer's statutory rights and does not affect those rights in any way.

FRANÇAIS

GARANTIE

Pour des informations sur la garantie, contacter le distributeur local Marantz.

CONSERVER L'ATTESTATION D'ACHAT

L'attestation d'achat est la preuve permanente d'un achat de valeur. La conserver en lieu sur pour s'y reporter aux fins d'obtention d'une couverture d'assurance ou dans le cadre de correspondances avec Marantz.

IMPORTANT

Pour l'obtention d'un service couvert par la garantie, il incombe au client d'établir la preuve de l'achat et d'en corroborer la date. Le reçu ou la facture constituent des preuves suffisantes.

DEUTSCH

GARANTIE

Bei Garantiefragen wenden Sie sich bitte an Ihren Marantz-Händler.

HEBEN SIE IHRE QUITTING GUT AUF

Die Quittung dient Ihnen als bleibende Unterlage für Ihren wertvollen Einkauf. Das Aufbewahren der Quittung ist wichtig, da die darin enthaltenen Angaben für Versicherungszwecke oder bei Korrespondenz mit Marantz angeführt werden müssen.

WICHTIG!

Bei Garantiefragen muß der Kunde eine Kaufunterlage mit Kaufdatum vorlegen. Ihre Quittung oder Rechnung ist als Unterlage ausreichend.

NEDERLANDS

GARANTIE

Voor inlichtingen omtrent garantie dient u zich tot uw plaatselijke Marantz.

UW KWITANTIE, KASSABON E.D. BEWAREN

Uw kwitantie, kassabon e.d. vormen uw bewijs van aankoop van een waardevol artikel en dienen op een veilige plaats bewaard te worden voor evt. verwijzing bijv. in verband met verzekering of bij correspondentie met Marantz.

BELANGRIJK

Bij een evt. beroep op de garantie is het de verantwoordelijkheid van de consument een gedateerd bewijs van aankoop te tonen. Uw kassabon of factuur zijn voldoende bewijs.

ESPAÑOL

GARANTIA

Para obtener información acerca de la garantía póngase en contacto con su distribuidor Marantz.

GUARDE SU RECIBO DE COMPRA

Su recibo de compra es su prueba permanente de haber adquirido un aparato de valor. Este recibo deberá guardarlo en un lugar seguro y utilizarlo como referencia cuando tenga que hacer uso del seguro o se ponga en contacto con Marantz.

IMPORTANTE

Quando solicite el servicio otorgado por la garantía el usuario tiene la responsabilidad de demostrar cuándo efectuó la compra. En este caso, su recibo de compra será la prueba apropiada.

ITALIANO

GARANZIA

L'apparecchio è coperto da una garanzia di buon funzionamento della durata di un anno, o del periodo previsto dalla legge, a partire dalla data di acquisto comprovata da un documento attestante il nominativo del Rivenditore e la data di vendita. La garanzia sarà prestata con la sostituzione o la riparazione gratuita delle parti difettose.

Non sono coperti da garanzia difetti derivanti da uso improprio, errata installazione, manutenzione effettuata da personale non autorizzato o, comunque, da circostanze che non possano riferirsi a difetti di funzionamento dell'apparecchio. Sono inoltre esclusi dalla garanzia gli interventi inerenti l'installazione e l'allacciamento agli impianti di alimentazione.

Gli apparecchi verranno riparati presso i nostri Centri di Assistenza Autorizzati. Le spese ed i rischi di trasporto sono a carico del cliente.

La casa costruttrice declina ogni responsabilità per danni diretti o indiretti provocati dalla inosservanza delle prescrizioni di installazione, uso e manutenzione dettagliate nel presente manuale o per guasti dovuti ad uso continuato a fini professionali.

SVENSKA

GARANTI

För information om garantin, kontakta Marantz lokagent.

SPAR KVITTOT

Kvittot är rätt inköpsbevis på en värdefull vara. Detskal förvaras säkert och hänvisas till vid försäkringsfall eller vid korrespondens med Marantz.

VIKTIGT

Fö att garantin skall gälla är det kundens sak att framställa bevis och datum om köpet. Kvitto eller faktura är tillräckligt bevis för detta.

CE MARKING

- English**
The PM7003/PM8003 is in conformity with the EMC directive and low-voltage directive.
- Français**
Le PM7003/PM8003 est conforme à la directive EMC et à la directive sur les basses tensions.
- Deutsch**
Das Modell PM7003/PM8003 entspricht den EMC-Richtlinien und den Richtlinien für Niederspannungsgeräte.
- Nederlands**
De PM7003/PM8003 voldoet aan de EMC eisen en de vereisten voor laag-voltage.
- Español**
El PM7003/PM8003 está de acuerdo con las normas EMC y las relacionadas con baja tensión.
- Italiano**
Il PM7003/PM8003 è conforme alle direttive CEE ed a quelle per i bassi voltaggi.
- Svenska**
PM7003/PM8003 är tillverkad i enlighet med EMC direktiven och direktiven för lågvoltstrusning.

English

WARNINGS

- Do not expose the equipment to rain, moisture, dripping or splashing.
- Do not remove the cover from the equipment.
- Do not insert anything into the equipment through the ventilation holes.
- Do not handle the mains cord with wet hands.
- Do not cover the ventilation with any items such as tablecloths, newspapers, curtains, etc.
- No naked flame sources, such as lighted candles, should be placed on the equipment.
- When disposing of used batteries, please comply with governmental regulations or environmental public instruction's rules that apply in your country or area.
- Make a space of about 0.2 meter around the unit.
- No objects filled with liquids, such as vases, shall be placed on the equipment.
- When the switch is in the OFF position, the equipment is not completely switched off from MAINS.
- The equipment shall be installed near the power supply so that the power supply is easily accessible.
- Do not touch hot spots during and immediately after use.
- During and immediately after use, this product is hot in areas other than the controls and rear panel connection jacks. Do not touch hot spots and especially the top panel. Contact with hot areas can cause burns.
- Do not expose the unit and batteries to excessive heat such as direct sunlight, fire or the like.

Français

AVERTISSEMENTS

- Ne pas exposer l'appareil à la pluie, à l'humidité, à l'égouttement ou aux éclaboussures.
- Ne pas essayer de retirer le boîtier de l'appareil.
- Ne rien insérer dans l'appareil par les orifices de ventilation.
- Ne pas manipuler le cordon d'alimentation avec les mains mouillées.
- Ne pas recouvrir les ouïes de ventilation avec un objet quelconque comme une nappe, un journal, un rideau, etc.
- Ne placer aucune source de flamme nue, comme une bougie allumée, sur l'appareil.
- Pour mettre au rebut les piles usées, respecter les lois gouvernementales ou les règlements officiels concernant l'environnement qui s'appliquent à votre pays ou région.
- Veiller à ce qu'aucun objet ne soit à moins de 0,2 mètre des côtés de l'appareil.
- Aucun objet rempli de liquide, un vase par exemple, ne doit être placé sur l'appareil.
- Lorsque l'interrupteur est sur la position OFF, l'appareil n'est pas complètement déconnecté du SECTEUR (MAINS).
- L'appareil sera installé près de la source d'alimentation, de sorte que cette dernière soit facilement accessible.
- Ne pas toucher aux zones chaudes pendant et immédiatement après l'utilisation.
- Pendant l'utilisation et immédiatement après, cet appareil est chaud en dehors des commandes et des prises de raccordement arrière. Ne pas toucher aux zones chaudes, et particulièrement au panneau supérieur, pour éviter tout risque de brûlure.
- N'exposez pas l'appareil et les piles à une chaleur excessive, comme par exemple aux rayons directs du soleil, au feu, etc.

Deutsch

WARNHINWEISE

- Das Gerät nicht Regen, Feuchtigkeit, Tropf- oder Spritzwasser aussetzen.
- Die Abdeckung nicht vom Gerät abnehmen.
- Keine Gegenstände durch die Belüftungsschlitze stecken.
- Das Netzkabel nicht mit feuchten oder nassen Händen anfassen.
- Decken Sie die Lüftungsöffnungen nicht mit einem Tischtuch, einer Zeitung, einem Vorhang usw. ab.
- Es dürfen keine Gegenstände mit offener Flamme, wie etwa brennende Kerzen, auf dem Gerät aufgestellt werden.
- Beachten Sie bei der Entsorgung der verbrauchten Batterien alle geltenden lokalen und überregionalen Regelungen.
- Auf allen Geräteseiten muß ein Zwischenraum von ungefähr 0,2 meter vorhanden sein.
- Auf das Gerät dürfen keine mit Flüssigkeiten gefüllte Behälter, wie etwa eine Vase, gestellt werden.
- Wenn der Schalter ausgeschaltet ist (OFF-Position), ist das Gerät nicht vollständig vom Stromnetz (MAINS) abgetrennt.
- Das Gerät sollte in der Nähe einer Netzsteckdose aufgestellt werden, damit es leicht an das Stromnetz angeschlossen werden kann.
- Berühren Sie während oder unmittelbar nach dem Gebrauch keine heißen Stellen des Gerätes.
- Während oder unmittelbar nach dem Gebrauch ist dieses Produkt mit Ausnahme der Bedienelemente und der Anschlussbuchsen auf der Rückseite heiß. Berühren Sie die heißen Stellen und insbesondere die Oberseite nicht. Der Kontakt mit heißen Flächen kann zu Verbrennungen führen.
- Setzen Sie das Gerät und die Batterien keiner übermäßigen Wärme aus, z.B. durch Aufstellung in direkter Sonneneinstrahlung, in der Nähe eines offenen Feuers usw.

Nederlands**WAARSCHUWINGEN**

- Stel het apparaat niet bloot aan regen, vocht, druppels of spetters.
- Verwijder de afdekplaat van het apparaat niet.
- Duw niets door de ventilatieopeningen in het apparaat.
- Raak het netsnoer niet met natte handen aan.
- Bedek de ventilatieopeningen niet met enige voorwerpen, zoals tafelkleden, kranen, gordijnen, enz.
- Plaats geen brandende voorwerpen, zoals kaarsen, op het apparaat.
- Volg bij het weggooiden van gebruikte batterijen de overheidswetgeving of milieuvorschriften op die van kracht zijn in het land of de regio waarin u zich bevindt.
- Zorg dat er 0,2 meter vrije ruimte rond het toestel is.
- Plaats geen voorwerpen met een vloeistof erin, zoals een bloemenvaas, op het apparaat.
- Als de schakelaar op OFF staat, is het apparaat niet volledig losgekoppeld van de netspanning (MAINS).
- De apparatuur wordt in de buurt van het stopcontact geïnstalleerd, zodat dit altijd gemakkelijk toegankelijk is.
- Raak hete gedeeltes van het apparaat niet aan tijdens en onmiddellijk na het gebruik.
- Tijdens en onmiddellijk na het gebruik is dit product heet, behalve in de omgeving van de bedieningstoetsen en de aansluitingen op het achterpaneel. Raak geen hete plekken aan, vooral niet het bovenpaneel. Contact met hete plekken kan brandwonden veroorzaken.
- Stel het apparaat en de batterijen niet bloot aan grote warmte, zoals direct zonlicht, vuur en dergelijke.

Español**ADVERTENCIAS**

- No exponga el equipo a la lluvia, la humedad, goteos o salpicaduras.
- No extraiga la tapa del equipo.
- No introduzca nada en el interior del equipo a través de los orificios de ventilación.
- No maneje el cable de alimentación con las manos mojadas.
- No cubra la ventilación con objetos como manteles, periódicos, cortinas, etc.
- No deben colocarse sobre el equipo elementos con fuego, por ejemplo velas encendidas.
- Cuando se eliminen baterías usadas, deben cumplirse las reglamentaciones oficiales o las normas de protección medioambiental aplicables en su país o en su zona.
- Deje un espacio de unos 0,2 metro alrededor de la unidad.
- No se deben colocar sobre el aparato recipientes que contengan líquidos, como por ejemplo jarrones.
- Cuando el interruptor está en la posición OFF, el equipo no está completamente desconectado de la alimentación MAINS.
- El equipo se instalará cerca de la fuente de alimentación de manera que resulte fácil acceder a ella.
- No tocar las áreas calientes mientras la unidad está en uso ni inmediatamente después.
- Mientras esta en funcionamiento e inmediatamente después de su uso, este producto presenta zonas calientes en diversas partes, no exclusivamente en el sector de los controles o en las conexiones del panel posterior. No tocar las áreas calientes, especialmente el panel superior dado que pueden producirse quemaduras.
- No exponga la unidad y las pilas a un calor excesivo, tal como el derivado de la luz directa del sol, el fuego, o alguna fuente térmica similar.

Italiano**AVVERTENZE**

- Non esporre l'apparecchio alla pioggia, all'umidità, al gocciolamento o agli spruzzi.
- Non rimuovere il coperchio dell'apparecchio.
- Non introdurre oggetti all'interno dell'apparecchio attraverso i fori di ventilazione.
- Non toccare il cavo di alimentazione con le mani bagnate.
- Non coprire le fessure di ventilazione con tovaglie, giornali, tende od oggetti analoghi.
- Non posare sull'apparecchio sorgenti di fiamme scoperte quali candele accese.
- Smaltire le pile usate in conformità alle norme governative o disposizioni ambientali vigenti nel proprio paese o zona.
- Lasciare 0,2 metro liberi tutto intorno l'unità.
- Non mettere sull'apparecchiatura alcun contenitore di liquido, come ad esempio dei vasi.
- Quando l'interruttore è nella posizione OFF, l'apparecchiatura non è completamente scollegata da MAINS.
- L'apparecchio va installato in prossimità della fonte di alimentazione, in modo che quest'ultima sia facilmente accessibile.
- Non toccare i punti caldi né durante, né immediatamente dopo l'uso.
- Durante, e subito dopo l'utilizzo, questo prodotto risulta essere molto caldo in alcune sue parti come ad esempio i connettori del pannello posteriore. Non toccare i punti caldi e specialmente la superficie del pannello. Il contatto con parti calde può provocare ustioni.
- Non esporre l'unità e le batterie a calore eccessivo come la luce diretta del sole, il fuoco o così via.

Svenska**VARNINGAR**

- Utsätt inte utrustningen för regn, fukt, droppande vatten eller vattenstänk.
- Ta inte bort utrustningens hölje.
- För inte in föremål i utrustningen genom ventilationshålen.
- Hantera inte nåtsladden med våta händer.
- Täck inte för ventilationsöppningarna med några föremål som till exempel bordsdukar, dagstidningar, gardiner e.d.
- Inga föremål med öppen låga, som till exempel tända stearinljus, bör placeras på utrustningen.
- Följ de lagar och miljöskyddsråd som gäller i det land eller område där du bor när du gör dig av med batterier.
- Se till att det finns omkring 0,2 meter fri plats runt omkring enheten.
- Inga objekt som är fyllda med någon vätska, till exempel blomstervaser, bör placeras på apparaten.
- Även om strömbrytaren står i det avstängda läget OFF, så är utrustningen inte helt bortkopplad från det elektriska nätet (MAINS).
- Utrustningen ska vara installerad nära strömuttaget så att strömförsörjningen är lätt att tillgå.
- Vidrör inte varma punkter under och omedelbart efter användning.
- Bortsett från kontrollerna och anslutningsuttagen på baksidan är den här produkten varm under och omedelbart efter användning. Vidrör inte varma punkter och särskilt inte ovansidan. Kontakt med varma ytor kan orsaka brännskador.
- Utsätt inte enheten och batterierna för kraftig värme, såsom direkt solljus, eld eller liknande.

AMP_080602N1

INTRODUCTION

Thank you for selecting the Marantz PM7003/PM8003 Integrated amplifier for your Audio system. Please read these operating instructions carefully. We recommend that you read the entire user guide before you attempt to connect or operate the amplifier. After you have reviewed the contents of this manual, we suggest that you make all system connections before you attempt to operate the unit.

ACCESSORIES CHECK

Before use, check the below accessories were included in the package.

- Remote controller
- User Guide

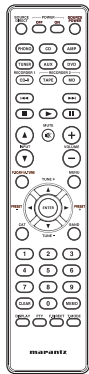

- Size "AAA" batteries x 2

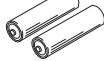

- AC Power cord

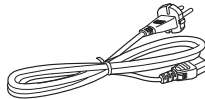

A NOTE ABOUT RECYCLING



This product's packaging materials are recyclable and can be reused. This product and the accessories packed together are the applicable product to the WEEE directive except batteries. Please dispose of any materials in accordance with your local recycling regulations. When discarding the unit, comply with your local rules or regulations. Batteries should never be thrown away or incinerated but disposed of in accordance with your local regulations concerning chemical wastes.

CONTENTS

- FEATURES** 2
 - FEATURES OF THE PM7003 AND PM8003 2
 - FEATURES OF THE PM8003 2
- BEFORE USE** 2
 - USAGE OF REMOTE CONTROLLER 3
- NAMES AND FUNCTIONS** 4
 - FRONT PANEL 4
 - REMOTE CONTROLLER 5
 - REAR PANEL 6
- BASIC CONNECTIONS** 7
 - CONNECTING AUDIO COMPONENTS 7
 - CONNECTING SPEAKER SYSTEMS 8
 - WIRING SPEAKER CABLE 8
 - CONNECTING OF AC POWER CABLE 8
- BASIC OPERATION** 9
 - PLAYBACK 9
- ADVANCED CONNECTIONS** 10
 - CONNECTING POWER DIRECT IN JACKS 10
 - CONNECTING PRE OUT JACKS 10
 - BI-WIRE CONNECTIONS 11
 - CONNECTING REMOTE CONTROL JACKS 11
- REMOTE CONTROLLER OPERATION** 12
- TROUBLESHOOTING** 13
- OTHERS** 14
 - SPECIFICATIONS & DIMENSIONAL DRAWINGS 14

FEATURES

FEATURES OF THE PM7003 AND PM8003

ALL-DISCRETE CURRENT-FEEDBACK AMPLIFIER

Marantz' proprietary current-feedback circuit, using discrete components, is adopted in the pre amplifier and power amplifier. It is a high-speed amplifier using the latest technology developed for the higher-grade amplifiers.

HDAM-SA3 TECHNOLOGY

The V/I converter circuit, which is the key block of the current-feedback pre-amplifier and power amplifier, is equivalent to the HDAM-SA3 amp-module developed for such higher-grade models as the SC-11S1.

CD DIRECT BUFFER AMPLIFIER

An input buffer amplifier exclusive for CD is mounted near the CD input jacks. This is a high-speed buffer amplifier made with discrete components, which avoids interference between right and left channels and can send the signals to the pre-amplifier with very high fidelity.

IMPROVED MOMENTARY CURRENT SUPPLY ABILITY

It is generally known that the sound quality is not necessarily the same even if amplifiers have the same specifications. Marantz considers the cause to be the power to drive speakers. The power amplifier of this unit has the ability to momentarily supply current of 25 A or more to drive speakers strongly.

SHORT-POWER-LINE LAYOUT

For strong momentary current supply, a short power-line layout unifies the power circuit and output stage of the power amplifier section. This layout allows connecting the large-current lines via the shortest route while to arranging the left and right channels symmetrically.

FEATURES OF THE PM8003

ALL-DISCRETE CURRENT-FEEDBACK PHONO EQUALIZER

As a phono equalizer amplifier for MM cartridges, a constant current-feedback PHONO equalizer of quality equal to that of the higher-grade model SC-11S1 is used.

DOUBLE-SHIELDED TOROIDAL TRANSFORMER

The unit is equipped with a toroidal power transformer to minimize vibration and leakage flux specific to the transformer. Especially to reduce leakage flux, which affects sound quality, the periphery is double-shielded, using a core ring and a short ring.

BLOCK CONDENSER OF LARGE CAPACITY

A large-capacity condenser of 18,000 μ F is used in the power circuit of the power amplifier. In the pre-amplifier, a 4700 μ F condenser is used.

HIGH-PERFORMANCE VOLUME

CAPACITOR FOR HIGH QUALITY SOUND

DOUBLE-LAYERED CHASSIS

HIGH-GRADE SPEAKER TERMINALS

COPPER-FINISHED CHASSIS

BEFORE USE

This section must be read before any connection is made to the mains supply.

EQUIPMENT MAINS WORKING SETTING

Your Marantz product has been prepared to comply with the household power and safety requirements that exist in your area. PM7003/PM8003 can be powered by 230V AC only.

COPYRIGHT

Recording and playback of any material may require consent. For further information refer to the following:

- Copyright Act 1956
- Dramatic and Musical Performers Act 1958
- Performers Protection Acts 1963 and 1972
- Any subsequent statutory enactments and orders

DO NOT LOCATE IN THE FOLLOWING PLACES

To ensure long-lasting use, do not locate the unit where:

- Exposed to direct sunlight.
- Near to sources of heat such as heaters.
- Highly humid or poorly ventilated.
- Dusty.
- Subjected to mechanical vibrations.
- On wobbly, inclined or otherwise unstable surfaces
- Radiated heat is blocked such as in cramped audio racks.

To ensure proper heat radiation, ensure the below clearance from walls and other equipment.

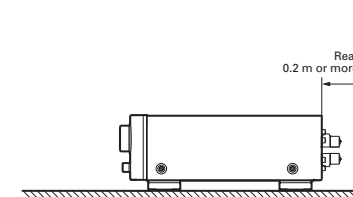
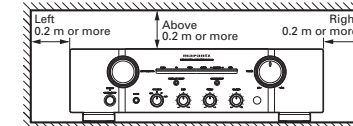

KEEP OBJECTS OFF

Keep objects off the unit. Blocking the vent can result in accident and damage.

DO NOT TOUCH HOT SPOTS DURING AND IMMEDIATELY AFTER USE

During and immediately after use, the unit is hot in areas other than the controls and rear panel connection jacks. Do not touch hot spots and especially the top panel. Contact with hot areas can cause burns.

USAGE OF REMOTE CONTROLLER**LOADING BATTERIES**

Before using the remote controller for the first time, load the batteries in the remote controller. The batteries provided are used to verify the operations of the remote controller only.

1. Remove the battery cover.

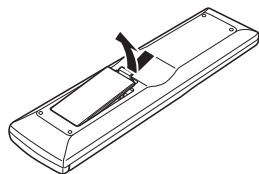

2. Insert the batteries with correct +/- orientation.

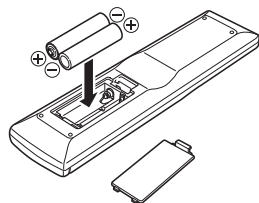

3. Close the battery cover until it clicks shut.

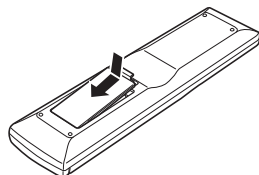
**CAUTIONS ON HANDLING BATTERIES**

Misuse of the batteries can result in electrolyte leakage, rupturing, corrosion, etc. Bear in mind the following points when using batteries.

- Remove the batteries from the remote control unit if the unit is not going to be used for a prolonged period (a month or more).
- Do not use an old battery together with a new one.
- Insert the batteries while ensuring that their \oplus and \ominus poles are properly aligned with the corresponding markings on the remote control unit.
- Batteries with the same shape may have different voltages. Do not use different types of batteries together.
- If electrolyte has leaked, thoroughly wipe the inside of the battery compartment, and then insert new batteries.
- When batteries which are no longer required are to be discarded, follow the directions (regulations) laid down by the local authorities in the area concerned for their disposal.

OPERATIONAL RANGE

Operate the unit with the remote controller within the range of the illustration below.

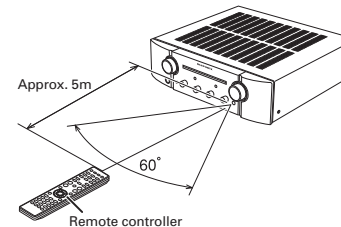
**Precautions**

- Do not allow direct sunlight, an inverter fluorescent light or other strong source of light to shine onto the player's infrared signal reception window (remote sensor). Otherwise, the operation of the remote control unit may be disabled.
- Bear in mind that operating the remote control unit may cause other devices operated by infrared rays to be operated by mistake.
- The remote control unit cannot be operated if the space between the controller and the player's remote sensor is obstructed.
- Do not place any objects on top of the remote control unit. Doing so may cause one or more buttons to be held down which will cause the batteries to run down.

NAMES AND FUNCTIONS

FRONT PANEL

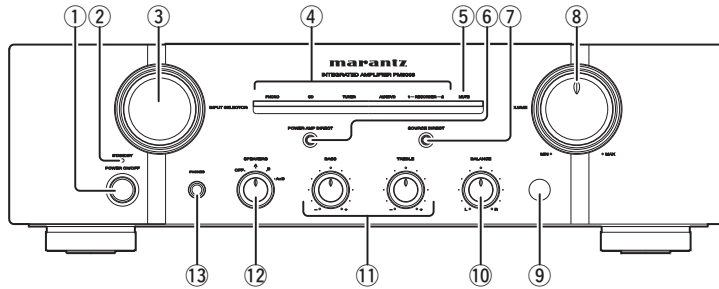

① POWER ON/OFF button

Pressing this button once turns power to the amplifier ON, and pressing it again turns power to the amplifier OFF. When the button is in the ON position, power can be switched ON/OFF using the remote controller.

If the power is switched OFF using the remote controller, the amplifier engages in standby mode. When in this mode, you cannot switch the power ON by pressing the POWER ON/OFF button. The amplifier remains in standby mode even if this button is pressed. To switch the power ON, either turn the INPUT SELECTOR knob or press the POWER ON button on the remote controller.

② STANDBY indicator

This indicator is lit red when the amplifier is in standby mode. When in standby mode, you can switch the power ON by using the POWER ON button on the remote controller. If the amplifier's protective circuit activates, this indicator flashes.

③ INPUT SELECTOR knob

This knob selects the input source for playback. The selected input source is displayed on the function indicator. The amplifier memorize the selected input source when the power is turned OFF, and then re-selects the same input source when the power is turned ON again.

④ Function indicator

This indicator displays the input source currently selected by the INPUT SELECTOR knob.

⑤ MUTE indicator

When the MUTE button on the remote controller is pressed, the MUTE function is activated and the volume is lowered. Pressing the MUTE button again releases the MUTE function. Moreover, the MUTE function can also be released by pressing the VOLUME +/- button on the remote controller. If the amplifier's protective circuit activates, this indicator flashes for approx. 15 seconds and the MUTE function activates. While this indicator is flashing, the VOLUME knob automatically turns and the volume decreases.

⑥ POWER AMP DIRECT button

The POWER DIRECT IN jacks are provided on the rear panel of the unit. Holding this button pressed for more than 3 seconds lights the indicator around the button, and this unit functions as the power amplifier.

In this status, the sound volume cannot be adjusted by turning the VOLUME knob. To release POWER AMP DIRECT mode, hold this button pressed for more than 3 seconds again.

⑦ SOURCE DIRECT button

Pressing this button lights the indicator around the button. The signal bypasses the balance and tone control circuits, boosting sound quality. When this button is set to ON, the BALANCE, BASS, and TREBLE knobs are disabled.

⑧ VOLUME knob

Turning this knob clockwise increases the volume, while turning it counterclockwise decreases the volume. The volume can also be adjusted using the remote controller. If the amplifier's protective circuit activates, the VOLUME knob automatically turns for approx. 15 seconds and the volume decreases.

⑨ Infrared Receptor Window

This is the receptor of control signals sent from the remote controller. Point the remote controller towards this window to properly transmit signals.

⑩ BALANCE knob

This knob is used to adjust the sound level from one of either the L (left) or R (right) channels. If the BALANCE knob is turned all the way round to one side, sound is not output from the opposite side.

Please note that this knob does not function when the SOURCE DIRECT button is in the ON position.

⑪ Tone Control knobs (BASS/TREBLE)

These knobs are used to adjust the BASS and TREBLE sound level. Turning the knobs clockwise increases the sound level, and turning them counterclockwise decreases the sound level. Please note that these knobs do not function when the SOURCE DIRECT button is in the ON position.

⑫ SPEAKERS knob

This knob is for selecting the speakers connected to the SPEAKERS SYSTEM A and/or B terminals on the rear panel. When you use headphones, set the knob to OFF.

⑬ PHONES jack

This jack is for connecting headphones with a standard stereo plug. To listen with headphones, turn the speaker output OFF by setting the SPEAKERS knob in the OFF position.

NAMES AND FUNCTIONS

REMOTE CONTROLLER

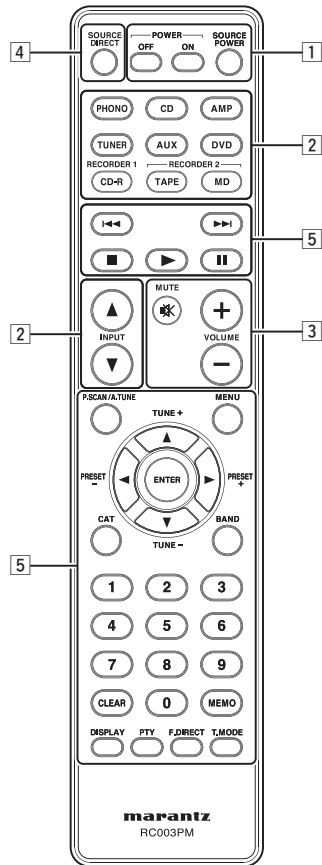

Using this remote controller, you can control this unit and Marantz CD players, DVD players, tuners, tape decks etc. that have a remote control receptor. The operations possible by remote controller may differ with each component; therefore see the instruction manual that came with the component.

The remote controller buttons are laid out as shown below.

1 POWER ON/STANDBY buttons

POWER ON button

Turns the unit power on when it is in the standby mode.

POWER OFF button

Sets the unit power to the standby mode when it is set to the power-on mode.

SOURCE POWER button

Switching the mode of a CD player, DVD player or other Marantz component equipped with a power standby function between power-on and standby is enabled by pressing this button after the INPUT SOURCE button corresponding to the component has been pressed.

When this button is pressed after pressing the TUNER button, the tuner's power is turned on; when it is pressed again, the tuner is set to the standby mode.

When this button is pressed after pressing the AMP button, the unit is switched from the power-on mode to the standby mode or vice versa.

* The remote controller cannot be used to turn the primary power of the amplifier ON and OFF.

2 Input selector buttons

Input source Button

These buttons are for directly selecting the input source.

Caution:
Some input jacks of this unit and the corresponding input selector buttons on the remote controller differ, as shown below.

The unit	Buttons on the remote controller
AUX/DVD	AUX, DVD
RECORDER2	TAPE, MD

For the input sources shown in the table above, although the same jacks are used for two types of sources on the unit, separate buttons are provided on the remote controller.

When using the remote controller for operation of a Marantz component connected to the unit, select the input source first, then perform operations.

INPUT ▲ Button

This button is for forward-feeding the input source indications to select a desired source.

The input source indication, which is displayed on the function indicator on the main frame, is fed to the right.

INPUT ▼ Button

This button is for backward-feeding the input source indications to select a desired source.

The input source indication, which is displayed on the function indicator on the main frame, is fed to the left.

3 VOLUME adjustment buttons

MUTE Button

This button activates the mute function. Pressing this button again releases the MUTE function.

The MUTE function can also be released by pressing either the VOLUME + or – buttons.

VOLUME + Button

This button increases the volume level.

VOLUME – Button

This button decreases the volume level.

4 SOURCE DIRECT button

This button is for switching Source Direct mode ON or OFF.

5 Component operating buttons

These buttons are for performing basic operations of a Marantz CD player, DVD player, etc. The function of each button changes to match the component selected as the input source using the input selector buttons.

For details, see page 12.

NAMES AND FUNCTIONS

REAR PANEL

PM8003

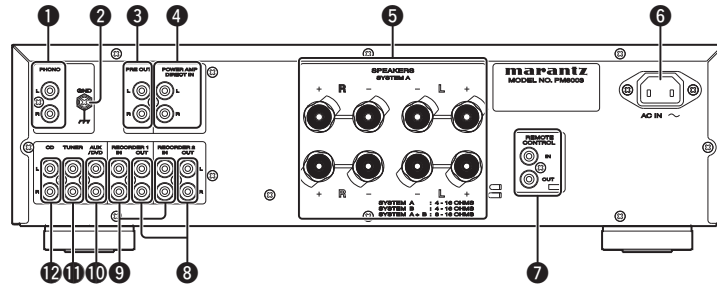

1 PHONO Input jacks

These jacks are for connecting to an analog record player. MM cartridges can be used.

2 PHONO GND terminal

Connect the grounding wire from an analog record player.

3 PRE OUT jacks

These jacks are for connection via the input jacks of another main amplifier or active subwoofers. These jacks cannot be used in Power Amp Direct mode.

4 POWER AMP DIRECT IN jacks

These jacks are used as input jacks when you use this unit as a power amplifier in Power Amp Direct mode. If you use another preamplifier, connect it via these jacks. In this status, the sound volume cannot be adjusted by turning the VOLUME knob.

5 SPEAKERS SYSTEM A, B output terminals

You can connect 2 speaker systems, SYSTEM A and SYSTEM B. Speaker output can be turned ON/OFF from the SPEAKERS knob on the front panel.

6 AC IN socket

Connect the supplied AC power cable to this socket and a power outlet.

7 REMOTE CONTROL jacks

These jacks are for connecting to other Marantz components such as a CD player or DVD player that has a remote control connector (D.BUS jack). You can use the remote controller supplied with the unit to control the system. For more details, see page 11.

8 RECORDER 1/RECORDER 2 output jacks

These jacks are for connecting to the recording input jacks of a CD-R recorder, MD deck, tape deck, etc.

PM7003

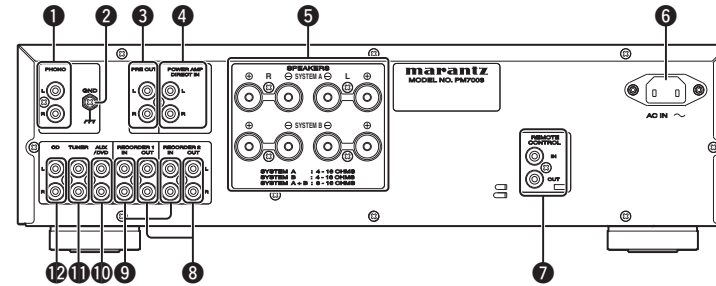

9 RECORDER 1/RECORDER 2 input jacks

These jacks are for connecting to the output jacks of a CD-R player, MD deck, tape deck, etc.

10 AUX/DVD input jacks

These jacks are for connecting to the output jacks of a DVD player or other audio component.

11 TUNER input jacks

These jacks are for connecting to the output jacks of a tuner or other audio component.

12 CD input jacks

These jacks are for connecting to the output jacks of a CD player or similar component.

BASIC CONNECTION

BASIC OPERATION

ADVANCED CONNECTIONS

REMOTE CONTROLLER OPERATION

TROUBLESHOOTING

OTHERS

BASIC CONNECTIONS

CONNECTING AUDIO COMPONENTS

Caution:

- Do not connect the power cord of this amplifier or any of the other components to the power supply until all of the connections are completed.
- Insert the plugs of the connections cords firmly into the connecting jacks. Incorrect insertion may cause noise.
- Connect the wires correctly to the L (left) and R (right) channels.
- Make sure that input and output are connected correctly.
- Refer also to the instruction manuals of components to connect equipment correctly.

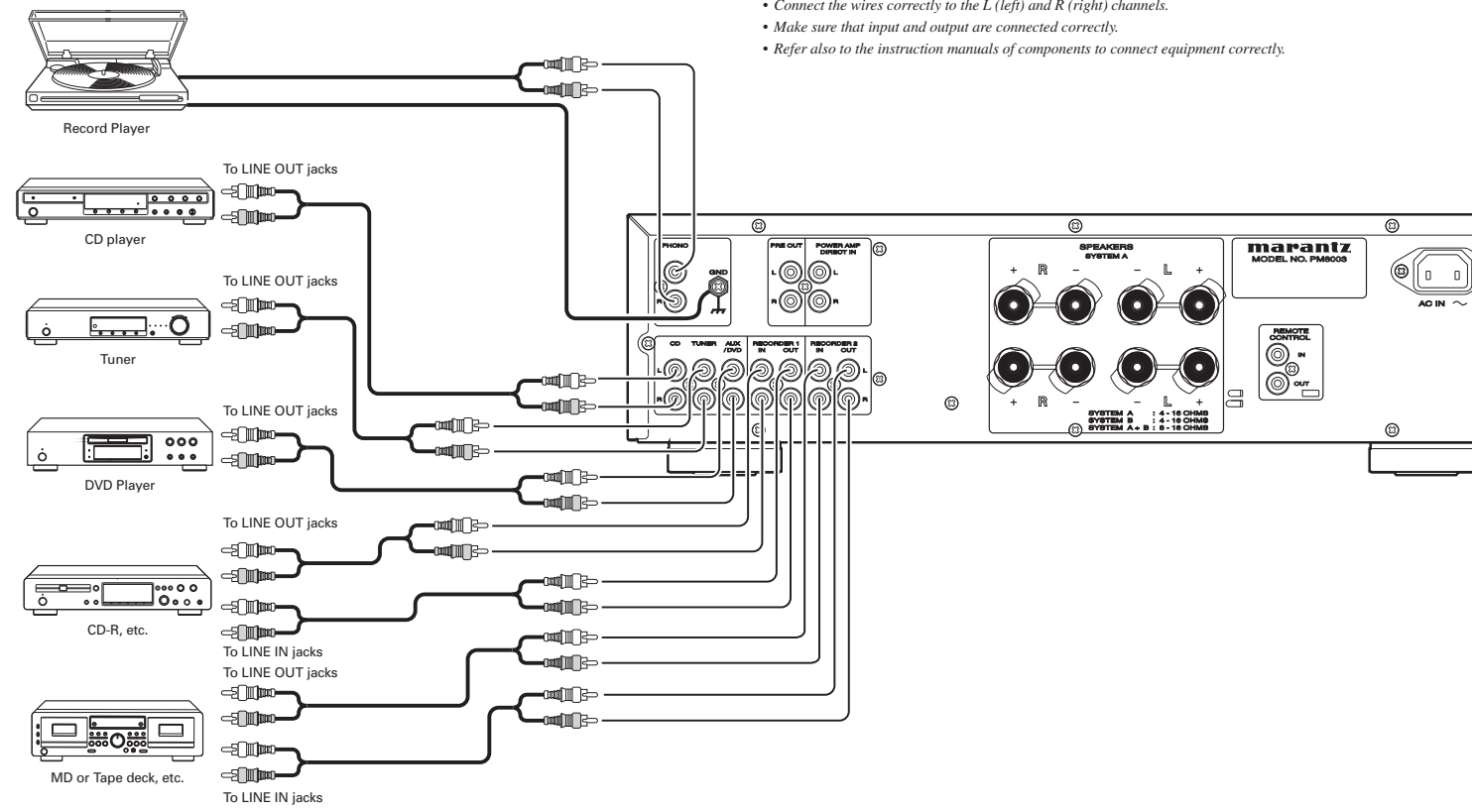

NAMES AND FUNCTIONS

BASIC CONNECTION

BASIC OPERATION

ADVANCED CONNECTIONS

REMOTE CONTROLLER OPERATION

TROUBLESHOOTING

OTHERS

BASIC CONNECTION

CONNECTING SPEAKER SYSTEMS

Your speaker system must satisfy the below conditions. If it does not, this unit's protective circuit will activate, whereby preventing proper playback. In some cases, the amplifier and speakers may be damaged.

- If using 1 set of speakers, total speaker impedance must be 4 Ω or more.
- If using 2 sets of speakers, total speaker impedance must be 8 Ω or more.

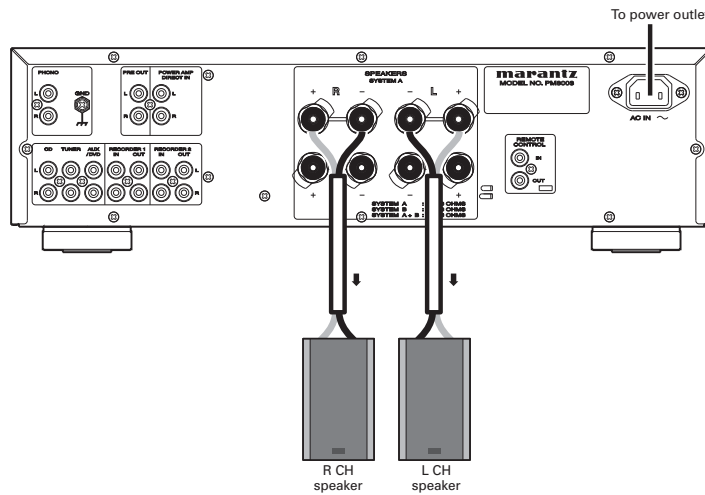

- Set the **SPEAKERS** knob on the front panel in the A or A+B position.

Notes:

- To prevent damage to circuitry, do not let the bare speaker wires touch each other and do not let them touch any metal part of this unit.

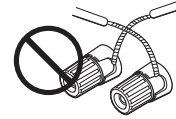

- Do not touch the speaker terminals when the power is on. It may cause you to receive an electric shocks.
- Be sure to connect the positive and negative cables for the speaker properly. If they are miss-connected, the signal phase will be reversed and the signal quality will be corrupted.

WIRING SPEAKER CABLE

- Peel off the coating of speaker cable as shown below.

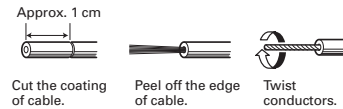

- Wiring with speaker cable.

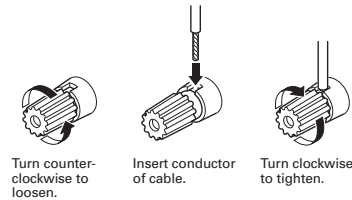

CONNECTING OF AC POWER CABLE

1. Plug the supplied AC power cable to the AC IN socket on the rear panel of the main unit.

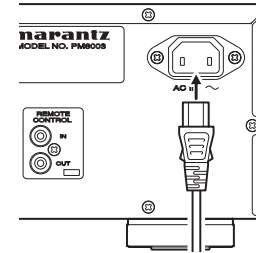

2. Plug the power cable into an AC outlet.

BASIC OPERATION

PLAYBACK

To explain how to play back input sources, representative examples are given with an CD player and analog record player. Before starting either procedure, check the component is correctly connected to the unit.

DISC PLAYBACK ON AN CD PLAYER

1. Press the power ON/OFF button of the CD player to activate power to it.
2. Press the **POWER ON/OFF** button ① to activate power to it. Approximately 8 seconds after power has been activated, the muting turns OFF and audio output is enabled.
3. Select the **CD** with the **INPUT SELECTOR** knob ③.
4. To use the speakers connected to the **SPEAKERS SYSTEM** terminals, set the **SPEAKERS** knob ⑫.
5. Load a disc into the CD player and press the play button to start playback.
6. Adjust the volume with from the **VOLUME** knob ⑧.
7. Adjust bass/treble as desired with the **BASS** and **TREBLE** knobs ⑪. Be sure to first set the **SOURCE DIRECT** button ⑦ in the **OFF** position.

DISC PLAYBACK ON AN ANALOG RECORD PLAYER

1. Press the **POWER ON/OFF** switch ① to activate power to it. Approximately 8 seconds after power has been activated, the muting turns OFF and audio output is enabled.
2. Select "PHONO" as the input source with the **INPUT SELECTOR** knob ③. To prevent unexpected accidents, it is recommended to set the volume level to **MIN.** by turning the **VOLUME** knob ⑧ until muting the volume level.
3. MM type cartridges can be connected. Use a step-up transformer when using an MC cartridge.
4. To use the speakers connected to the **SPEAKERS SYSTEM** terminals, set the **SPEAKERS** knob ⑫.
5. Set a record on the analog record player and play it.
6. Adjust the volume level with the **VOLUME** knob ⑧.
7. Adjust bass/treble as desired with the **BASS** and **TREBLE** knobs ⑪. Be sure to first set the **SOURCE DIRECT** button ⑦ in the **OFF** position.

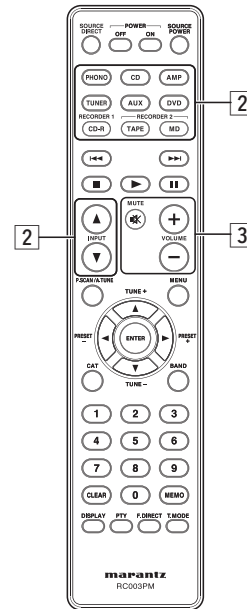
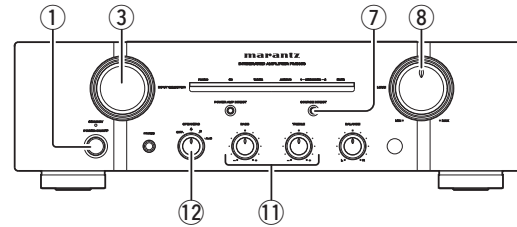

- NAMES AND FUNCTIONS
- BASIC CONNECTION
- BASIC OPERATION**
- ADVANCED CONNECTIONS
- REMOTE CONTROLLER OPERATION
- TROUBLESHOOTING
- OTHERS

ADVANCED CONNECTIONS

CONNECTING POWER DIRECT IN JACKS

If you use a preamplifier, connect it as shown below, and then you can use this unit as a power amplifier. Set the POWER AMP DIRECT IN button on the front panel of the unit to its ON position. For details on operations of the preamplifier, refer to the instruction manual supplied with the preamplifier to be used.

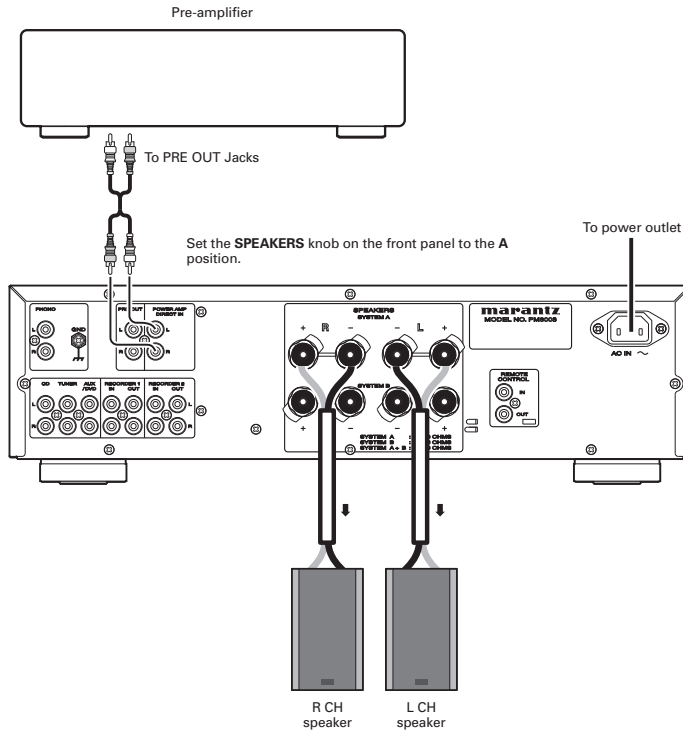

Note:

If you use this unit as a power amplifier, the preamplifier section does not function, and the **INPUT SELECTOR**, **SOURCE DIRECT**, **VOLUME**, **BASS**, **TREBLE**, and **BALANCE** knobs are disabled.

CONNECTING PRE OUT JACKS

If you use a power amplifier, connect it as shown below, and then you can use this unit as a preamplifier. For connecting speaker systems, refer to the instruction manual supplied with the power amplifier to be used.

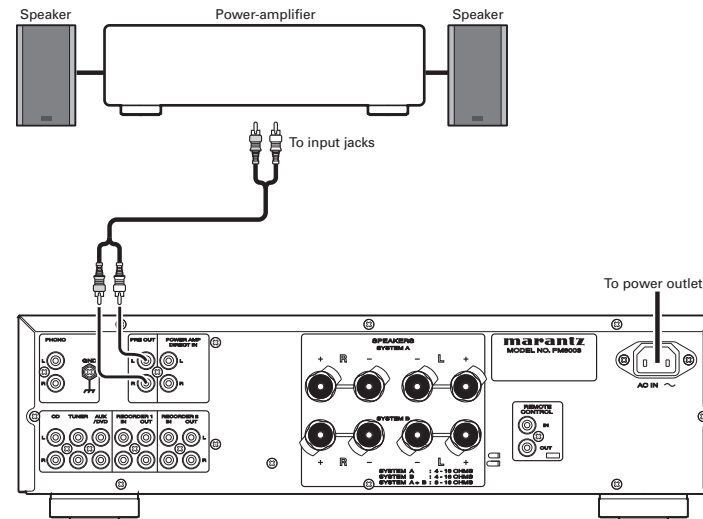

ADVANCED CONNECTIONS

BI-WIRE CONNECTIONS

BI-WIRE connection is a technique for improving sound quality. It connects speaker systems and an amplifier, using two speaker cables; one for mid-to-high range speakers and another for bass speakers. It eliminates the influence on a mid-to-high range speaker unit due to back electromotive force generated by the bass speaker unit.

For BI-WIRE connection, a speaker system must comply with the BI-WIRE connection specifications. Refer to the instruction manual supplied with the speaker system.

Connect a mid-to-high range speaker via the SYSTEM A terminals and a bass speaker via the SYSTEM B terminals. Then set the SPEAKER knob on the front panel in the A+B position.

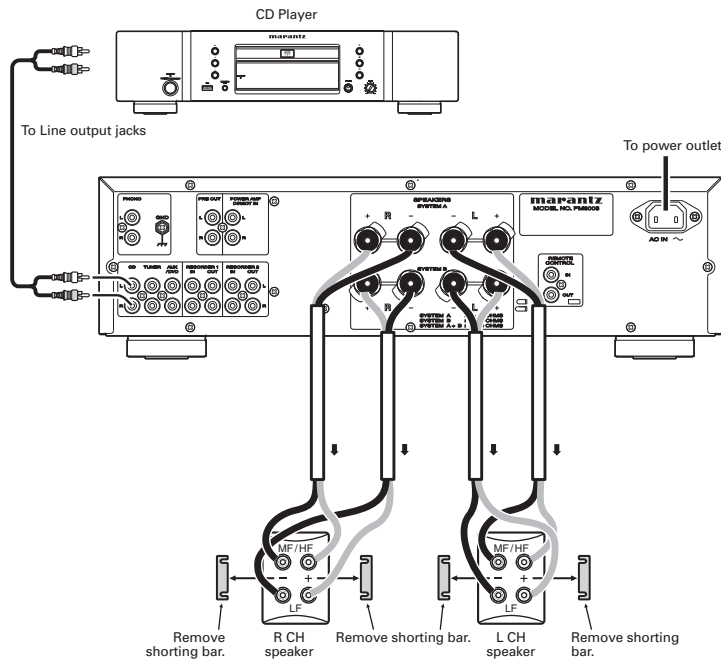

CONNECTING REMOTE CONTROL JACKS

The **REMOTE CONTROL** jacks are for connecting components that are capable of remote control (**D.BUS** jacks) such as a Marantz CD Player or DVD Player. This enables these other components to be operated with the remote controller included with the unit. The unit comes with the system remote controller that can operate the basic features of Marantz CD Players and DVD Players. Here, a brief explanation of how to control the unit and CD Player using this remote controller is provided. As shown in the illustration below, connect the **REMOTE CONTROL "IN"** jack of the CD Player to the **REMOTE CONTROL "OUT"** jack of the unit, and set the CD Player switch to "**EXTERNAL**". Both this model and CD Player can be operated by pointing the **remote controller** at the receptor of this model.

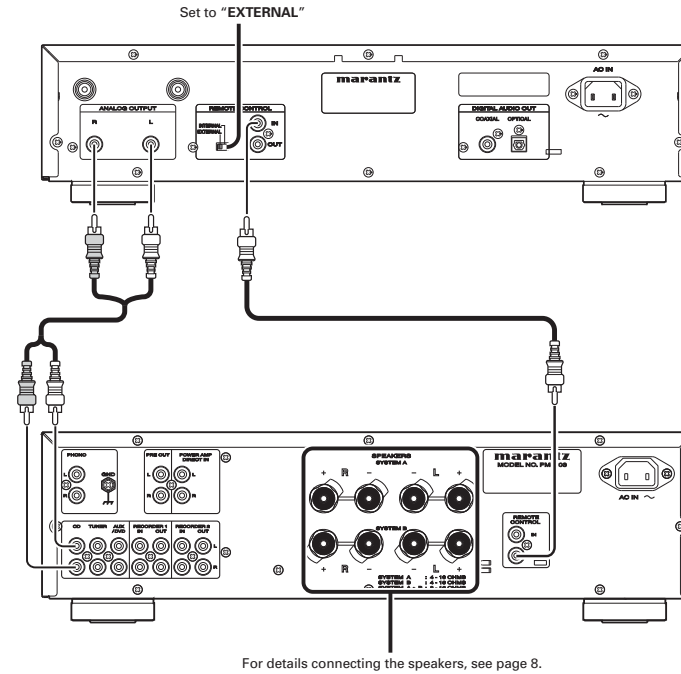

For details connecting the speakers, see page 8.

REMOTE CONTROLLER OPERATION

CD

When the CD button is pressed, the buttons in group [5] function as indicated in the table below. These buttons can only be used when a Marantz CD player is connected to the CD input jacks.

BUTTON NAME	FUNCTION
⏮	Skips to the start of the current track
⏭	Skips to the next track
■	Stops playback
▶	Starts playback
⏸	Pauses a disc that's playing
P.SCAN/A.TUNE	Not for use
MENU	Not for use
▲/TUNE+	Not for use
▼/TUNE-	Not for use
◀/PRESET-	Not for use
▶/PRESET+	Not for use
ENTER	Not for use
CAT	Not for use
BAND	Not for use
0-9	Inputs the numeric
CLEAR	Not for use
MEMO	Not for use
DISPLAY	Not for use
PTY	Not for use
F.DIRECT	Not for use
T.MODE	Selects the sound mode

TUNER

When the TUNER button is pressed, the buttons in group [5] function as indicated in the table below. These buttons can only be used when a Marantz tuner is connected to the TUNER input jacks.

BUTTON NAME	FUNCTION
⏮	Not for use
⏭	Not for use
■	Not for use
▶	Not for use
⏸	Not for use
P.SCAN/A.TUNE	Starts preset scan
MENU	Not for use
▲/TUNE+	Tuning (frequency) increase
▼/TUNE-	Tuning (frequency) decrease
◀/PRESET-	Preset stations forward feed
▶/PRESET+	Preset stations backward feed
ENTER	Not for use
CAT	Not for use
BAND	Selects the band
0-9	Inputs the numeric
CLEAR	Clears the inputting
MEMO	Enters the tuner preset memory numbers
DISPLAY	Selects the display mode in RDS
PTY	Displays the programme type information of the current station
F.DIRECT	Selects the "frequency direct input"
T.MODE	Selects the auto stereo mode or mono mode

DVD

When the DVD button is pressed, the buttons in group [5] function as indicated in the table below. These buttons can only be used when a Marantz DVD player is connected to the AUX/DVD input jacks.

BUTTON NAME	FUNCTION
⏮	Skips to the start of the current track or chapter
⏭	Skips to the next track or chapter
■	Stops playback
▶	Starts playback
⏸	Pauses a disc that's playing
P.SCAN/A.TUNE	Not for use
MENU	Displays a DVD disc menu
▲/TUNE+	Move the cursor upward
▼/TUNE-	Move the cursor downward
◀/PRESET-	Move the cursor leftward
▶/PRESET+	Move the cursor rightward
ENTER	Selects the current menu option
CAT	Not for use
BAND	Not for use
0-9	Inputs the numeric
CLEAR	Not for use
MEMO	Not for use
DISPLAY	Displays the disc playback information
PTY	Not for use
F.DIRECT	Not for use
T.MODE	Not for use

TAPE

When the RECORDER 2 (TAPE) button is pressed, the buttons in group [5] function as indicated in the table below. These buttons can only be used when a Marantz tape deck is connected to the RECORDER 2 (TAPE) jacks.

BUTTON NAME	FUNCTION
⏮	Fast backward
⏭	Fast forward
■	Stops playback
▶	Starts playback
⏸	Pauses a tape that's playing
P.SCAN/A.TUNE	Not for use
MENU	Not for use
▲/TUNE+	Not for use
▼/TUNE-	Not for use
◀/PRESET-	Not for use
▶/PRESET+	Not for use
ENTER	Not for use
CAT	Not for use
BAND	Not for use
0-9	Not for use
CLEAR	Resets counter
MEMO	Not for use
DISPLAY	Not for use
PTY	Not for use
F.DIRECT	Not for use
T.MODE	Not for use

TROUBLESHOOTING

BEFORE CONSIDERING IT AS A FAILURE

In case of trouble with this component, first check the following before calling for service. What seems to be a serious malfunction is often due to a simple operation mistake. If the trouble is not fixed after making the following checks, contact the place of purchase, your nearest Marantz dealer, our customer service center, or our repair service center.

Phenomenon	Causes	Actions
Power is not supplied.	The power cable is disconnected.	Check the power cable connections.
	The unit is in STANDBY mode.	Turn the INPUT SELECTOR knob or press the POWER ON button on the remote controller.
	The protection circuit is activated.	If the STANDBY indicator is flashing, turn the power OFF, then ON again after 1 minute or more.
Power is supplied, but no sound is heard from the speaker.	Speaker connection is incomplete.	Check the speaker cable connection.
	Input cord connection is incomplete.	Check the input cable connection.
	The INPUT SELECTOR knob is not set correctly.	Set the INPUT SELECTOR knob properly.
	The VOLUME knob is set to minimum.	Turn the VOLUME knob to the proper level.
	<ul style="list-style-type: none"> The SPEAKERS knob is set to OFF. Setting of the SPEAKERS knob is incorrect. 	Set the SPEAKERS knob properly according to the SPEAKER terminals to which the speakers are connected.
	Setting of the POWER AMP DIRECT button is incorrect.	Set the POWER AMP DIRECT button properly.
Sound is heard from left or right speakers only.	Speaker connection is incomplete.	Check the speaker connections.
	Setting of the BALANCE knob is incorrect.	Set the BALANCE knob properly.
Left and right channels are reversed.	Connection of left and right speaker cords or input cords is reversed.	Make connections properly.
Noise occurs during record playing.	Grounding connection from the record player is improper.	Check the connections to the PHONO GND terminal.
	Connection to the PHONO jacks is incorrect.	Check the connection to the PHONO input jacks.
Howling occurs when sound volume is increased during record playing.	A TV set or the like placed too close to the record player may affect the sound.	Place the TV set or record player in another position.
	Speakers are placed too close to the record player.	Place the speakers away from the record player as far as possible.
Howling occurs when sound volume is increased during record playing.	The record player is placed on a rack or floor that is easily vibrated.	If an insulating pad is not supplied with the record player, use an insulating pad available in the market.

ABOUT THE PROTECTIVE CIRCUIT

This unit is equipped with a protective circuit to protect the amplifier circuits and speaker system against damage. If the protective circuit is activated, the sound is instantly muted. In this case, either the MUTE indicator flashes, or the STANDBY indicator above the POWER ON/OFF button flashes.

AT POWER ON

For about 8 seconds after the power is turned on, the protective circuit is activated muting the sound to give the amplifier circuits time to stabilize. Once the amplifier circuits stabilize, the protective circuit releases and audio is enabled.

IN THE EVENT OF OVERCURRENT

The protective circuit is activated if current exceeding a certain level is detected, which can happen if excessive signal flow is input to the amplifier or if the unit is connected to a speaker system of less than 4Ω impedance. The protective circuit is also activated if a speaker cable shorts. In these cases, the MUTE indicator flashes, and the volume is automatically reduced. Approximately 15 seconds later the protective circuit is released, therefore the volume needs readjusting to continue normal use. Moreover, if the overcurrent continues, the amplifier's power shuts OFF and the STANDBY indicator above the POWER ON/OFF button flashes.

IF EXCESSIVE ULTRA-BASS SIGNALS ARE INPUT

The protective circuit is also activated if ultra-bass signals that exceed the base signal range settings are input. In this case, the MUTE indicator flashes, and the volume is automatically reduced. Approximately 15 seconds later, the protective circuit is released, therefore the volume needs readjusting to continue normal use. If excessive ultra-bass signal input continues or if DC voltage is detected due to trouble with the amplifier, the power shuts OFF and the STANDBY indicator above the POWER ON/OFF button flashes.

IF THE MAIN-AMPLIFIER OVERHEATS

The protective circuit is activated if the temperature of the main-amplifier section rises above a certain level, which can happen if the amplifier is continually used with excessive signal flow being input into it. The protective circuit is also activated when the set operating temperature is exceeded, which can happen if the vents on top of the amplifier are covered, or if the amplifier is installed on a cramped audio rack. In these cases, the MUTE indicator flashes, and the volume is automatically reduced. Approximately 15 seconds later, the protective circuit is released, therefore the volume needs readjusting to continue normal use. If the temperature does not sufficiently lower within a certain amount of time after the protective circuit activation, the power shuts OFF and the STANDBY indicator above the POWER ON/OFF button flashes.

IN THE EVENT OF AMPLIFIER TROUBLE

The protective circuit is activated and the power is automatically shut OFF if an abnormality is detected in the power circuit. The same happens if the main fuse inside the amplifier blows. In these cases, the STANDBY indicator above the POWER ON/OFF button flashes. In cases as mentioned above, immediately disconnect the power cord, and contact the place of purchase, your nearest Marantz dealer, our customer service center, or our repair service center.

OTHERS

SPECIFICATIONS & DIMENSIONAL DRAWINGS

Power output (20 Hz – 20 kHz simultaneous drive of both channels)
70W x 2 (8 Ω load)
100W x 2 (4 Ω load)
 Total harmonic distortion (20Hz – 20kHz simultaneous drive of both channels, 8Ω load)
 0.02%
 Output band width (8 Ω load, 0.05%)
5Hz – 60kHz
 Frequency response (CD, 1W, 8 Ω load)
 5Hz – 100kHz ±3dB
 Dumping factor (8 Ω load, 20Hz – 20kHz).....100
 Input sensitivity/Input impedance
 PHONO (MM)..... 2mV/47kΩ
 CD, LINE, TUNER, AUX/DVD, RECORDER
 200mV/20kΩ
 MAIN IN..... 1.6V/20kΩ
 Output voltage/Output impedance
 PRE OUT.....1.6V/600Ω
 Maximum allowable PHONO input level (1kHz)
 MM 100mV
 RIAA deviation (20Hz ~ 20kHz) ±0.5dB
 S/N (IHF-A, 1W, 8 Ω load)
 PHONO (MM)
 (PM7003)..... 85dB
 (PM8003)..... 87dB
 CD, LINE, TUNER, AUX/DVD, RECORDER
 (PM7003)..... 88dB
 (PM8003)..... 90dB
 POWER AMP DIRECT IN 106dB
 Tone control
 Bass (50Hz)..... ±10dB
 Treble (20kHz) ±10dB

Power requirement..... AC 230V 50Hz
 Power consumption
 (EN60065)..... 200W
 Standby power consumption 0.3W
 Accessories
 Remote controller.....1
 AAA batteries.....2
 Detachable AC power cable1
 Maximum outer dimensions (Amplifier)
 Width..... 440mm
 Height (PM7003)..... 126.8mm
 (PM8003)..... 128.3mm
 Depth (PM7003)..... 364mm
 (PM8003)..... 379mm
 Weight (Amplifier) 10.5kg

Specifications subject to change without prior notice.

PM8003

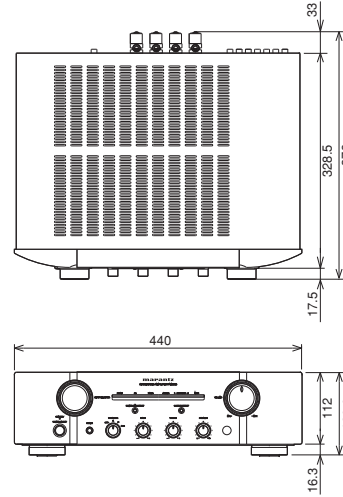

PM7003

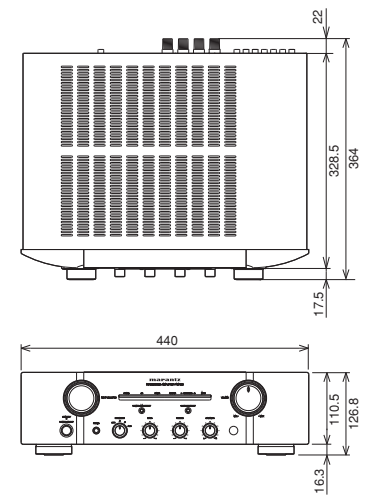

(unit : mm)

CLEANING OF EQUIPMENT EXTERNAL SURFACES

The exterior finish of your unit will last indefinitely with proper care and cleaning. Never use scouring pads, steel wool, scouring powders or harsh chemical agents (e.g., lye solution), alcohol, thinner, benzene, insecticide or other volatile substances as these will mar the finish of the equipment. Likewise, never use cloths containing chemical substances. If the equipment gets dirty, wipe the external surfaces with a soft, lint-free cloth.

If the equipment becomes heavily soiled:

- dilute some washing up liquid in water, in a ratio of one part detergent to six parts water.
- dip a soft, lint free in the solution and wring the it is damp.
- wipe the equipment with the damp cloth.
- dry the equipment by wiping it with a dry cloth.



REPAIRS

Only the most competent and qualified service technicians should be allowed to service the factory-trained warranty station personnel have the knowledge and special facilities needed for repair and calibration of this precision equipment. After the warranty period has expired, repairs will be performed for a charge if the equipment can be returned to normal operation.

In the event of difficulty, refer to your dealer or write directly to the nearest location to you that is listed on the Marantz Authorized Service Station list. If writing, please include the model and serial number of the equipment together with a full description of what you think is abnormal about the equipment's behaviour.

USING HEADPHONES

If the volume in the headphones is too high, it may injure your ears. Do not set the sound volume too high.

www.marantz.com

You can find your nearest authorized distributor or dealer on our website.

marantz[®] is a registered trademark.



Printed in China

06/2008 541110081032M mzh-d